



- BENEFITS**
- Table top machine
 - Easy to operate
 - Easy to clean
 - Low maintenance
 - HACCP



SCAN AND DISCOVER MORE INNOVATIONS IN THE NEW MEDIA CENTER

TARTLET

Produce the finest tart shells with the TARTLET SATELLITE by BAKON

Scan the QR code to watch the video!



Through energy-saving measures, such as dimensioning of electrical power and – where possible – use of recyclable materials, BAKON commits to dealing responsibly with the environment.



Scan the QR code to visit the BAKON website.



The TARTLET SATELLITE makes it easy to create sweet and savory tart shells that are much fresher, cheaper and of higher quality than the pre-baked shells you buy.

Bake the finest tart shells and enjoy fresh, beautiful coloured and shaped tart shells.

This digitally programmable automatic tart shell system makes the difference.



BAKON FOOD EQUIPMENT
Stanleyweg 1
4462 GN Goes
The Netherlands

Tel.: +31 (0)113 244 330
Fax: +31 (0)113 244 360
info@bakon.com
www.bakon.com

[19-392]



BAKON designs and produces standardized and customized depositing, spraying and cutting machines as well as production lines for efficient, high-volume processing of pastry products. BAKON stands for advanced technology and reliability.



After a warm up time of 15 minutes, it takes less than 10 minutes to shape and bake the finest tart shells. With a choice of 10 baking moulds it is possible to produce almost any shape or size. An additional feature of the Tartlet Satellite allows you to create sweet and savoury tart shells with an assortment of fillings to finish in the oven or freeze for later use.



The TARTLET SATELLITE is a table top stand-alone machine.



- Ready within 15 minutes (from 0 - 230 °C)
- Adjustable temperature for top and bottom plate
- Baking time is less than 10 minutes
- Teflon coated interchangeable baking moulds
- Up to 45 programmable products



Almost any type of dough



Available teflon coated baking moulds:

T5	ø 12.5 cm, 5 moulds	390 x 340 x 60 mm
T9	ø 9,0 cm, 9 moulds	390 x 340 x 60 mm
T12 waffles	ø 9.9 x 6.5 cm, 12 moulds	390 x 340 x 60 mm
T13	ø 8.0 cm, 13 moulds	390 x 340 x 60 mm
T15 boat	ø 10.0 x 4.5 cm, 15 moulds	390 x 340 x 60 mm
T24	ø 4.5 cm, 24 moulds	390 x 340 x 60 mm
T30	ø 4.2 cm, 30 moulds	390 x 340 x 60 mm
T35 square	32 x 32 mm, 35 moulds	390 x 340 x 60 mm
T35 eight angled	32 x 32 mm, 35 moulds	390 x 340 x 60 mm
T46 boat	ø 5.0 x 2.0 cm, 46 moulds	390 x 340 x 60 mm

Capacity: medium



Dimensions (l x w x h) : 490 x 440 x 395 mm
 Dimensions (l x w x h) : 19,3 x 17,3 x 15,5 inch
 Weight : 32 kg

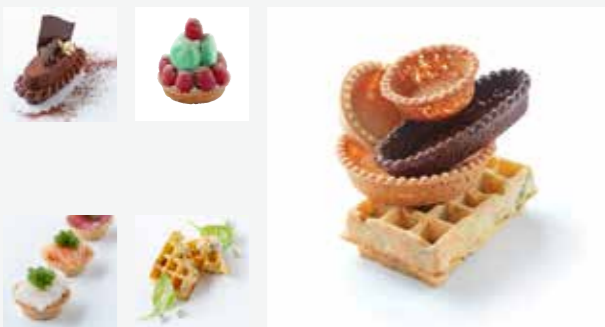
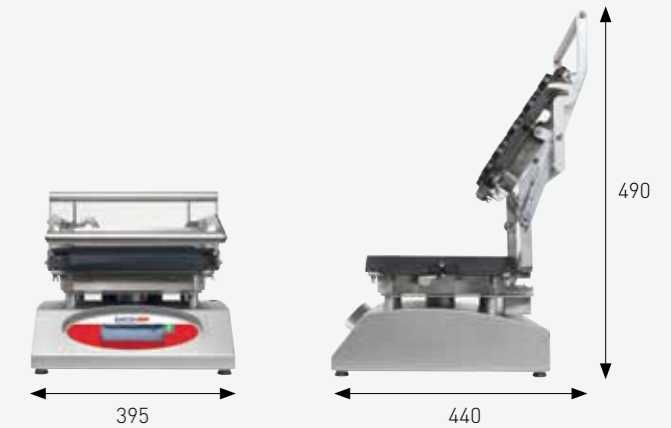

A

The Tartlet Satellite can store max. 45 programs by product name. Each with separate control of temperature of top and bottom plates and baking time.

B

Digitally adjustable baking time with automatic countdown in seconds and acoustic signal at the end of the baking time.

C Receptacle for abundant product



D Closing hook



E Wing nuts to attach the baking moulds.



F

